

INFRASOUND-SENSOR ADX III-INFO4LE user manual

Update 2023-4-9

SAYA Inc.
RESONA ALES

Table of contents

1. Overview	3
2. What's infrasound	4
2.1 Frequency	4
2.2 Resolution	4
2.3 Difference with low frequency noise meter	4
3. Basic specifications	5
3.1 Specifications	5
3.2 Connector	5
3.3 Interface setting	5
4. Sensor and data acquisition	6
4.1 Assignment of sensors and general-purpose analog inputs to input channels	6
4.2 Accelerometer	7
4.3 Infrasound Sensor (HF)	7
4.4 Temperature sensor	7
4.5 GPS 1PPS signal	8
4.6 Supply Voltage Monitor	8
4.7 Infrasound Sensor(LF)	8
4.8 Trigger ring buffer	8
4.9 Digital filter (analog input)	8
4.10 CARD_ID	9
5. Cautions and test methods for using infrasound sensors	9
5.1 Wind influences	9
5.2 Other environmental influences	9
5.3 Opening and closing the door	10
6. Buffer-triger Engine	14
6.1 Ring buffer (Analog and Counter input)	14
6.2 Multifunctional Trigger Controller	14
6.3 Block polling	15
6.4 Sampling timer	16
7. Software	17
7.1 How to handle this product	17
7.2 Configuration of Ethernet mode	17
7.3 Configuration of RS232C (UART) mode	20
7.4 Driver Installation Method	21
7.5 Usage of application and API, description of register map	21
7.6 DeviceInstaller	21
7.7 Maintenance of communication environment	23
8. Cautions, etc.	24

1. Overview

This product is an Ethernet / RS232C which has 2-interface switchable infrasound sensor and it is also equipped with an external GPS unit and sensors that affect infrasound such as 3-axis acceleration (vibration) and temperature sensors. Infrasound consists of two sensors: (1) 1000Hz ~ 0.1Hz ±71Pa capacitive differential pressure infrasound sensor and (2) 0.1Hz ~ DC (26Kpa ~ 126Kpa) precision barometer.

The data acquisition core is compatible with the Multifunction I / O-XIII series of ADXIII 42LE, and has common applications, APIs and register maps. This product can be handled by three methods: public register map, API of Windows driver (ADiox3-API), and application for Windows (MultLoggerX3).

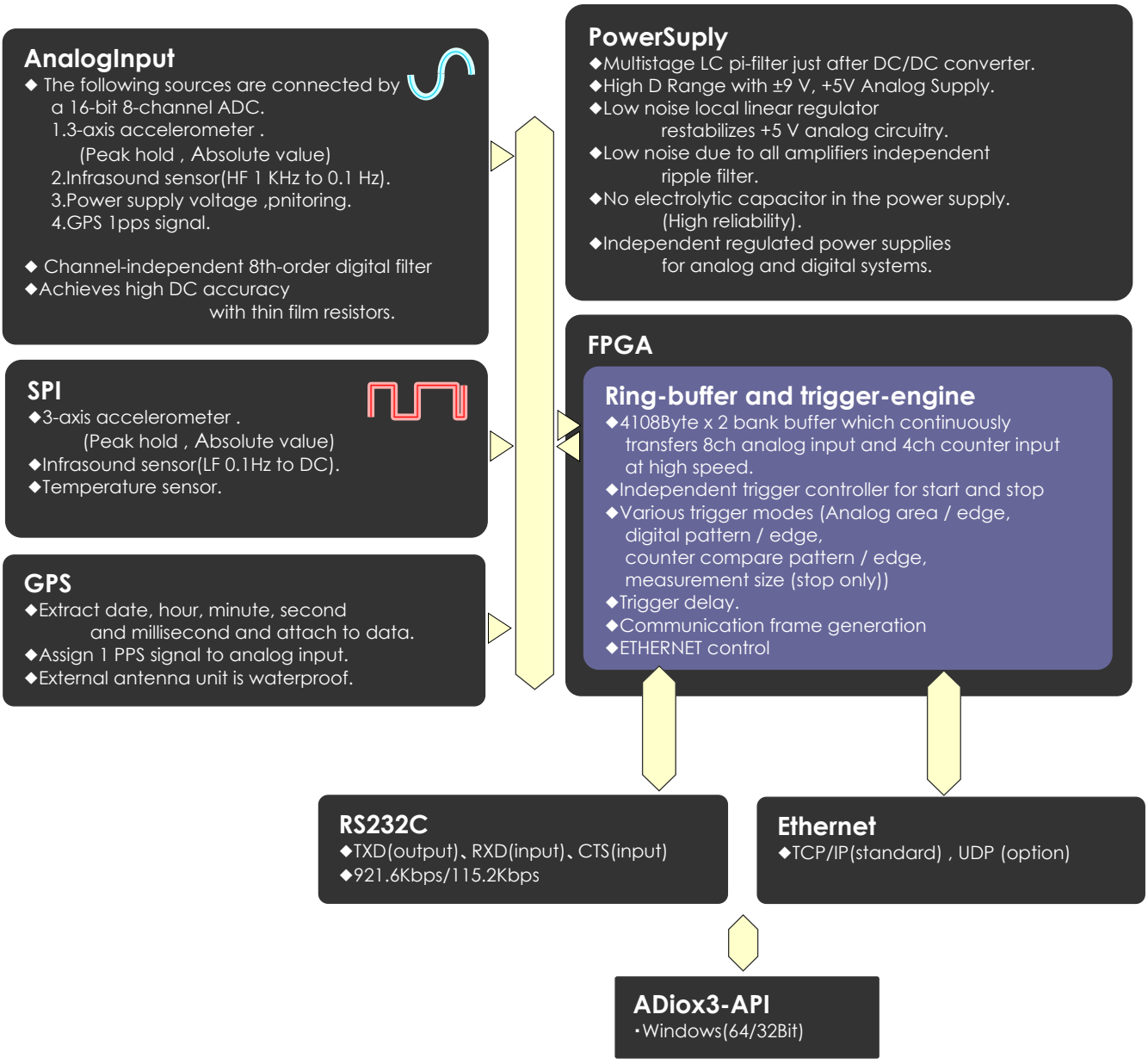

The following abbreviations are often used in the text.
Alxx stands for analog input xx channel.
AOxx stands for analog output xx channel.
Dlxx stands for digital input xx channel.
DOxx stands for digital output xx channel.
CTCxx stands for counter input xx channel.

2.What is Infrasound ?

2.1 Frequency

Infrasound is an ultra-low frequency sound (1 mHz to 100 Hz) lower than the human audio frequency range (20 Hz to 20 kHz), and it is possible to grasp various conditions related to geophysics. Typical examples include tsunamis, volcanic eruptions, earthquakes, landslides, meteorites and satellites entering the atmosphere, various artificial noises (wind power generation, explosion sounds, nuclear tests, etc.). In general, low-frequency sounds can reach far without decaying, so if you use infrasound, you can understand phenomena that occur far away. Naturally, the infrastructure sounds generated by various factors are mixed.

So, although analysis technology is also important, we have succeeded in developing technology that can detect only tsunamis with a single infrastructure sound sensor. Infrasound deals with frequencies much lower than the frequency range that can be measured by the microphone, so you need a dedicated sensor that is completely different from the microphone.

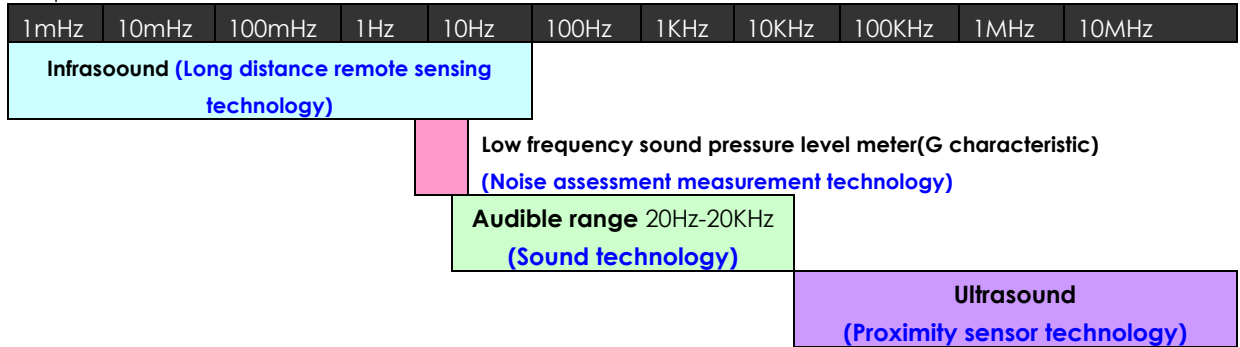

2.2 Resolution

Infrasound is often thought to be detectable by a barometer. However, the resolution of a general barometer is about 1Pa. On the other hand, the minimum resolution that we want to detect with an infrasound sensor is 1mPa. In this point, you will see that a dedicated sensor is required.

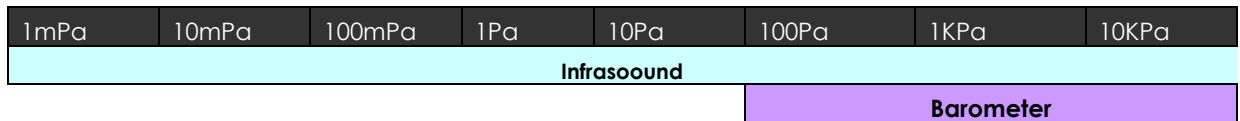

2.3 Difference with low frequency noise meter

There are low frequency noise meters in the market. However, this is a combination of the microphone and the audibility correction filter like G characteristic below. It is a sound level meter that emphasizes low frequency sound around 20 Hz. Because the sensitivity of the microphone below 20Hz is extremely low, it is impossible to measure low frequency noise with this. Such low frequency noise can also be elucidated more scientifically by using infrastructure sound.

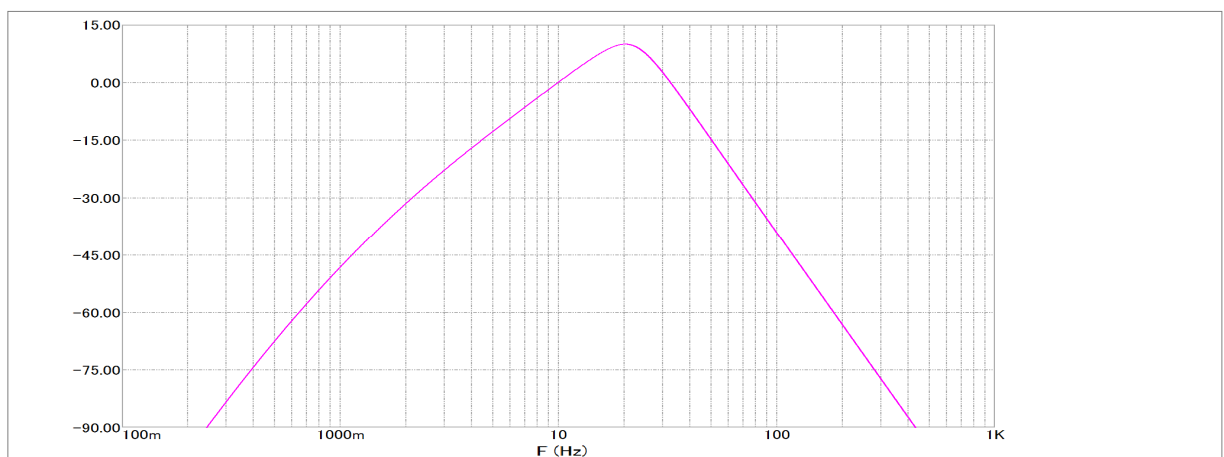

Frequency characteristics of low Low frequency sound pressure level meter (G characteristic). Vertical axis: level (dB), Horizontal axis: frequency (Hz)

Measure only a narrow frequency range centered on 20 Hz. The infrasound band can hardly be detected.

3. Basic specifications

3.1 Specifications

Dimensions : W128.4×D114.6×H28.9mm (not including connector protrusion)
 Power supply voltage : AC100-240V(50-60Hz)
 Power consumption : 2.5Wrms (Typical)
 Ambient temperature and humidity : -10 to 60 °C (operating) -20 to 125 °C (storage)
 : 10 to 90% RH (operating: no condensation)
 Communication method : Wired LAN (Ethernet), RS232C switching type
 Waterproof / drip-proof : This product is not waterproof or drip-proof.

3.2 Connector



- ① Air vent
- ② GPS unit connection terminal (D-SUB 9 pin male)
- ③ Ethernet connector
- ④ AC adapter connection jack (5.5-2.1)
- ⑤ RS232C/UART connector (D-SUB 9 pin male)

Pin number	Content
1	not connected
2	RS232C RXD (Input , Receiver)
3	RS232C TXD (Output , Transmitter)
4	not connected
5	Ground.
6	not connected
7	not connected
8	RS232C CTS (Input, Flow control)
9	not connected

Use a cross cable (for interlink) for the RS232C cable.

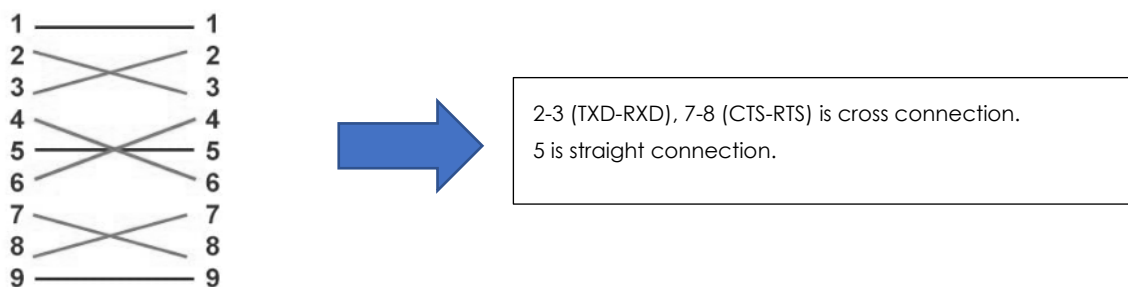

3.3 Interface settings

To switch Ethernet / RS232C 921.6 Kbps / RS232 C 115.2 Kbps, open the case and set the internal jumper. Before work, be sure to discharge your body's static electricity sufficiently and ground your body. Do not work while the power is on. First remove the four screws on the side of the case. The top of the case comes off and you can see the board. There is a jumper JP2 on the board. Please set as follows. Please close the case at the end.

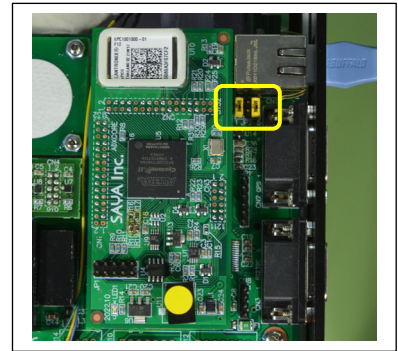
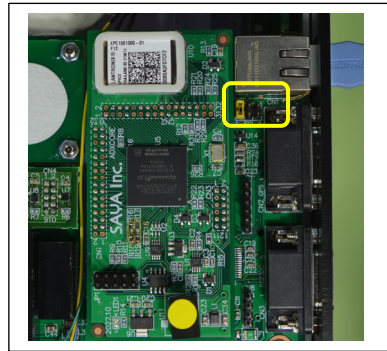
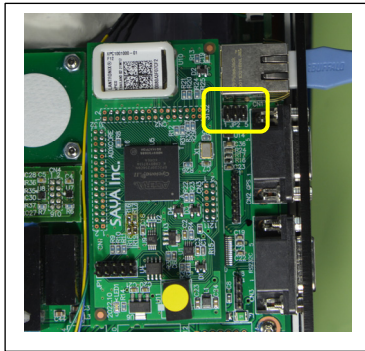
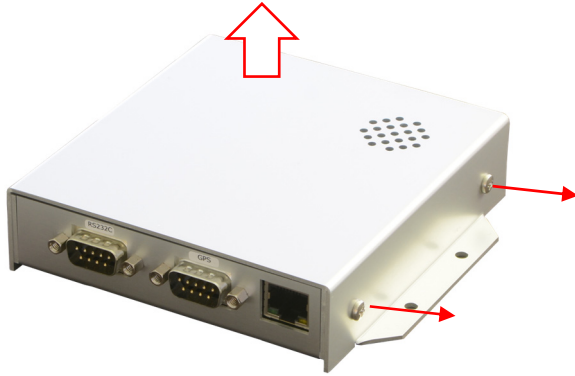

Ethernet

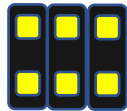

RS232C 921.6Kbps

RS232C 115.2Kbps

	ETHERNET	RS232C 921.6Kbps	RS232C 115.2Kbps
JP2 1-2	OFF	ON	ON
JP2 3-4	OFF	OFF	OFF
JP2 5-6	OFF	OFF	ON

4.Sensor and data acquisition

4.1 Assignment of sensors and general-purpose analog inputs to input channels

This product has built-in data acquisition function equivalent to our ADXIII42LE.

The signals from the infrastructure sound sensor and various sensors are connected to the I / O of this data acquisition function. Assignments are presented below.

(Hereafter, terms like AIx = analog input channel x, CTCx = counter input channel x are used.)

- AI0 axis acceleration(vibration) : X
- AI1 axis acceleration(vibration) : Y
- AI2 axis acceleration(vibration) : Z
- AI3 Infrasound HF (0.1Hz-1000Hz)
- AI4 Temperature
- AI5 GPS 1PPS signal
- AI6 Power-supply voltage
- AI7 No-connection
- CTC0 No-connection (Reserved ADXIII-INF01LE)
- CTC1 No-connection (Reserved ADXIII-INF01LE)
- CTC2 No-connection (Reserved ADXIII-INF01LE)
- CTC3 Infrasound LF (DC-0.1Hz)

4.2 Accelerometer

The figure below shows the equivalent circuit, which actually has this circuit for three axes (XYZ). The acceleration signal amplified by the preamplifier is converted to a digital signal by an A/D converter and passed through a peak hold circuit. Peak hold holds the peak value during polling (sampling), and the peak is reset each time data is read. This will not miss the peak even at slow polls.

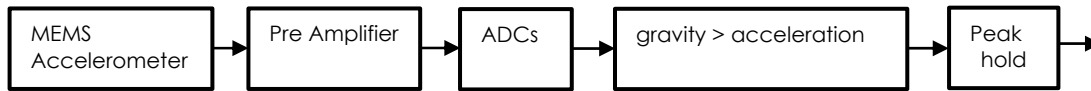

- Number of channels : 3 channels (3 axes of XYZ)
- Assignment : AI0-2
- ADC resolution : 15 bits
- Measurement range : 0 to 1960 Gal
- Frequency characteristics : 0.19Hz to 25Hz
- Noise : about 1.5 Gal or less
- Buffer trigger engine : High-speed transfer of 128 samples per bank
- Trigger source : AI0 (acceleration X)
- MultiLogger X3 sensor type : Select **"0-4096mV"**, set the scaling range,
: Please set to **Before conversion** "65535(Upper)-0(Lower)"
and **After conversion** "1960(Upper)-0(Lower)", please turn ON.
: The unit is Gal.

4.3 Infrasonic Sensor (HF)

The figure below shows the equivalent circuit. The sensor has multiple sound paths, is a phase equalizer, and after converting the delays of each sound path, converts it into an analog signal with a capacitive differential pressure gauge. The signal is then amplified by a preamplifier via a band pass filter of 0.012 Hz to 2800 Hz and converted to a digital signal by an A / D converter. The high frequency cutoff frequency is affected by the sampling frequency and the digital filter. Digital filters are hardware 8th and software 5th. The software 5th-order digital filter can not be used via the ring buffer.

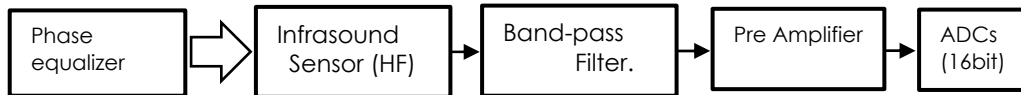

- Number of channels : 1 channel
- Assignment : AI3
- ADC resolution : 16 bits
- Maximum measurement sound pressure : 128 dB (± 71050 mPa = 50247.5 mPa rms)
- Noise level (ring buffer) : 21 mPa rms (digital filter Off, $F_s = 800$ Hz, 60 mPa pp) = S / N 76.6 dB
: 1.8 mPa rms (digital filter On, $F_s = 800$ Hz 5 mPa pp) = S / N 98 dB
- Frequency characteristics : 0.1 Hz to 1000 Hz (Analog circuit theoretical characteristics,
High frequency is limited by sampling frequency)
: 0.1 Hz to 320 Hz (Digital filter Off, $F_s = 800$ Hz)
: 0.1 Hz to 32.5 Hz (Digital filter On, $F_s = 800$ Hz)
: 0.1 Hz to 65 Hz (-3 dB digital filter On, $F_s = 800$ Hz)
: Frequency characteristics with digital filter,
if sampling frequency is f_s , approximate -3 dB frequency = $f_s / 12.8$,
Flat frequency = $f_s / 25.5$.
- Buffer trigger engine : High-speed transfer of 128 samples per bank
- MultiLogger X3 sensor type : Select **"0-4096mV"**, set the scaling range,
: Please set to **Before conversion** "71505(Upper)- -71050(Lower)" , please turn ON.
: The unit is mPa.

4.4 Temperature sensor

Equipped with a temperature sensor for monitoring the printed circuit board.

- Number of channels : 1 channel
- Assignment : AI4
- Noise level : 0.03°C
- ADC resolution : 16 bits
- Buffer trigger engine : High-speed transfer of 128 samples per bank
- MultiLogger X3 sensor type : Select **"0-4096mV"**, set the scaling range,
: Please set to **Before conversion** "65535(Upper)-0(Lower)"
and **After conversion** "655.35(Upper)- 0(Lower)", please turn ON.
: The unit is °C.

4.5 GPS 1PPS signal

The analog input becomes AI5, to which the GPS 1PPS signal is assigned.
Originally 1PPS signal is a digital signal, but this is assigned to an analog signal.

- Number of channels : 1 channel
- Assignment : AI5
- ADC resolution : 16 bits
- Input range : 0 to 16.384V
- Signal level : 0xEFFF (3840mV) , 0xD7FF (3456mV)
- Buffer trigger engine : High-speed transfer of 128 samples per bank
- MultiLogger X3 sensor type : Select "0-4096mV".
: Please set to **Before conversion** "65535(Upper)-0(Lower)"
and **After conversion** "4096(Upper)- 0(Lower)" , please turn ON.(default)

4.6 Supply Voltage Monitor

After dividing the power supply voltage to 1/4, it is connected to AI4. The circuit configuration after AI4 is the same as general-purpose analog input.

- Number of channels : 1 channel
- Assignment : AI6
- ADC resolution : 16 bits
- Input range : 0 to 16.384V
- Error : Up to 1.1%
- Buffer trigger engine : High-speed transfer of 128 samples per bank
- MultiLogger X3 sensor type : Select "0-4096mV".
: Please set to **Before conversion** "65535(Upper)-0(Lower)"
and **After conversion** "32.768(Upper)-0(Lower)" , please turn ON.
: The unit is V .

4.7 Infrasound Sensor(LF)

Aside from the aforementioned Infra Sound Sensor (HF), it is equipped with a high-precision absolute pressure gauge. Since it is only an FIR filter with a noise floor of 53 mPa rms, resolution of 24.4 mPa, and good phase characteristics (no IIR filter is used), it is also possible to add it to the Infrasound Sensor (HF).

- Number of channels : 1 channel
- Assignment : CTC3
- ADC resolution : 24 bits
- Measurement range : 260 hPa to 1260 hPa
- Noise level : 53 mPa rms (Fs = 800 Hz, 150 mPa pp)
- Resolution : 24.4 mPa
- Frequency characteristics : DC to 0.1 Hz
(theoretical value, 0.02 to 0.1 Hz is unknown
because there is no test environment)
- Buffer trigger engine : High-speed transfer of 128 samples per bank
- MultiLogger X3 sensor type : Select "4x encoder counter (Z used)".
: Please set to **Before conversion** "16,777,215(Upper)-0(Lower)"
and **After conversion** "4096(Upper)-0(Lower)" , please turn ON.
: The unit is hPa.

4.8 Trigger ring buffer

- Trigger type : Analog level (rising or falling or within range or out of range or dual edge),
: Digital (pattern (maskable) or rising edge or falling edge or both edges),
: Unconditional , stop counter (stop trigger only)
: ... Both start and stop can be set independently
- Pre-trigger : None
- Trigger delay : 0 to 65535
- Buffer size : 1027 double words × 2 banks
- Ring buffer target : AI 0 to 7 (128 samples each), CTC 0 to 3 (128 samples each),
: Temperature (1 sample), DI 0 to 15 (1 sample)

4.9 Digital filter (analog input)

After analog-to-digital conversion, you can select to pass the digital filter. The digital filter is an 8th-order FIR low-pass type, and each channel is independent. The right figure shows the frequency response when the sampling frequency is fs, for easy noise removal. Be careful when the frequency characteristic accuracy is required because the interruption characteristic is gentle. This filter does not have an anti-aliasing filter. So, when applying a frequency spectrum more than 1/2 of the sampling frequency, please input analog through anti-aliasing filter to prevent aliasing.

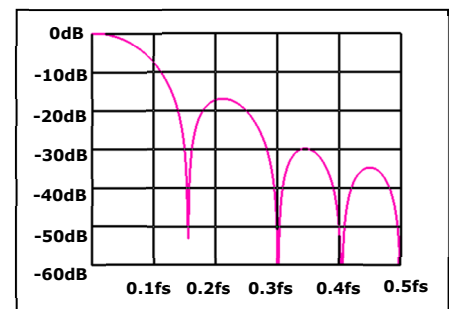

4.10 CARD_ID

The **ADXIII-INF04LE** is identified by the software-assigned IP address and the corresponding CARD_ID (0 to 3).

If you build a system with multiple **ADXIII-INF04LEs**, if there is a device whose power supply or communication is interrupted during operation, the corresponding **ADXIII-INF04LE** will be removed from the system and operation will be continued with the remaining devices. It has a dynamic grouping function that is automatically added to the system when the removed device comes back.

5. Cautions and test methods for using infrasound sensors

Please pay attention to the following points.

- Environment with little temperature change.
- Environment with little vibration.
- Environment that does not receive influence of wind directly.
- A room where doors are not open and close often.

5.1 Wind influences

The change in micro atmospheric pressure by the wind becomes the infrasound as it is. In the case of a strong wind, it will be a large value of around 50Pa.

There are several known ways to mitigate the effects of wind.

Distribute the intake surface with a pipe.

The micro atmospheric pressure change due to the wind can be offset by distributing and averaging the measurement position (intake position). As shown in the right figure, there is a way to extend the intake of the infrastructure sound sensor and place an octopus foot-like intake pipe there. There are two ways of intake pipe: 1) Intake from the lower end of the tip, 2) Porous pipe which absorbs slowly throughout the intake pipe. In the case of porous pipes, the intake pipe can be closed to prevent insects from entering. In any case, the longer the air intake pipe at the octopus foot, the more the effects of wind can be reduced. In general, it seems that the diameter is often about 3m to 30m.

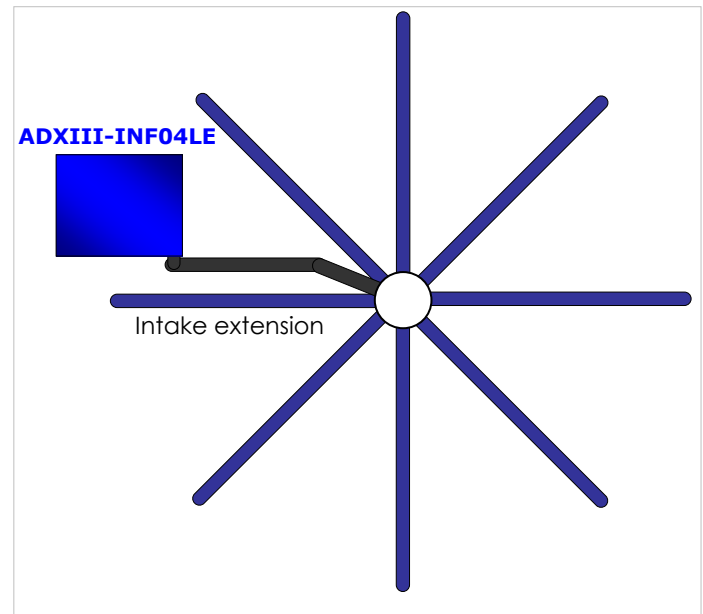

Distribute sensors

The sensors themselves are placed at intervals of several hundred meters to several kilometers, and combined with the above-mentioned method of distributing the intake air by averaging the measured values of these sensors.

Put in the room

Even when the wind is outside, the room is calm. This is because the room itself acts as a filter for the wind. In the experiment, a reduction effect of 1/2 to 1/5 was obtained. Although it is less effective than the aforementioned intake dispersion, it may be sufficient depending on the measurement content. In addition, as it is easy to make it waterproof, dustproof, and supply power to the device, it is a method with great advantages. Please note the following points for indoor installation.

- ◆ The measuring room is not completely sealed. (Air vent etc. are required)
- ◆ Beware of pressure changes due to opening and closing of the door (The pressure of the room changes greatly. In a room with few entering and leaving, the opening and closing of the door should be managed slowly and quietly)

5.2 Other environmental influences

Other than wind, it is affected by the following.

- Sudden change in altitude (altitude causes pressure change)
- Vibration (Big vibrations cause noise by shaking the sensor diaphragm) Since this product has an acceleration sensor, it can be determined whether it is due to vibration or not.
- Rapid temperature change in a room with high degree of sealing
(Temperature change causes air to expand and contract, leading to pressure change)
Since this product has a temperature sensor, it can be separated whether it is the influence of temperature or not.
- Effects of standing waves (When installed in a building, sound waves shorter than the room size will naturally be affected by standing waves)
- Meteorological atmospheric pressure change (Infrasound sensor LF is a barometer equivalent, so it naturally responds to atmospheric pressure. Infrasound sensor HF also responds to sudden pressure changes)

5.3 Opening and closing the door

Below is the waveform of the Infrasond (HF) capacitive differential pressure gauge when data is collected at $F_s = 800$ Hz via the ring buffer, with the door of the room suddenly opening and closing normally.



As the door opens only, it is unlikely that the same positive pressure as negative pressure will occur. However, it can not be helped because it is a differential pressure gauge with a low frequency of about 0.1 Hz. So we add it to Infrasond (LF), an absolute pressure gauge. The absolute pressure gauge is hPa so it is multiplied by 100,000 and added.

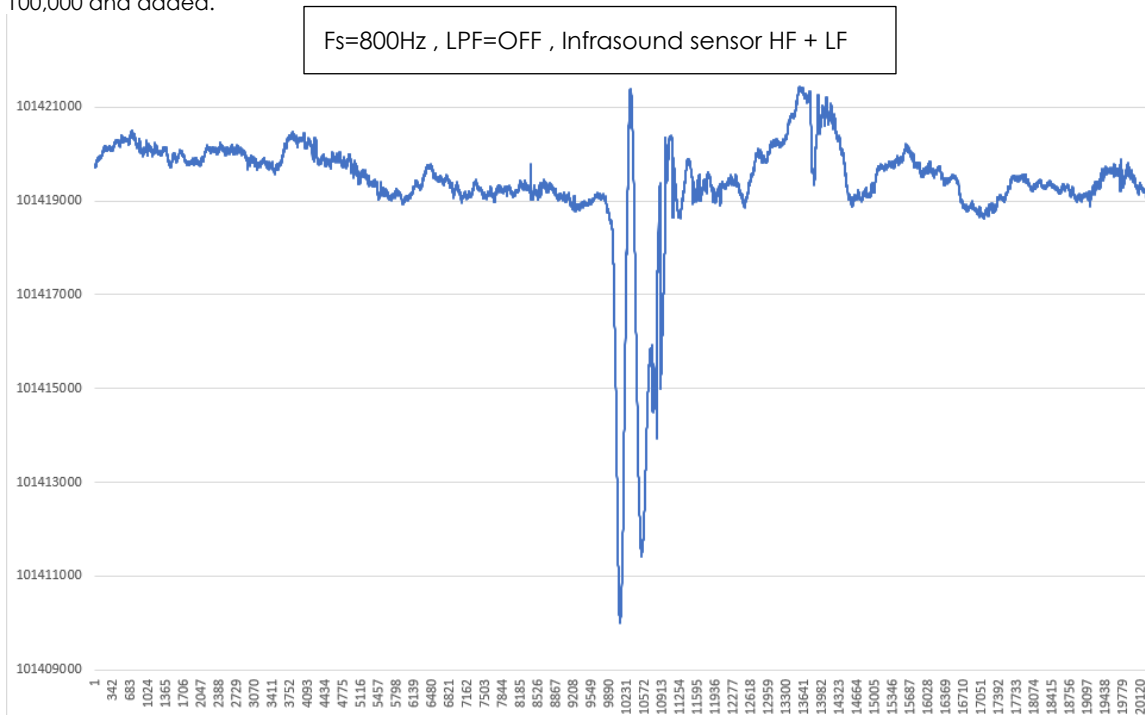

The swing return from negative pressure has been reduced. This kind of synthesis is possible because LF (absolute pressure gauge side) has the same noise level as HF side (capacitance type differential pressure gauge). In addition, both the HF and LF sides are linear phase characteristics which do not use IIR digital filters, Butterworth or Chebyshev analog filters, so it is possible to simply add waveforms.

Next, at the infrasound (HF), let's use a low pass filter. The waveform has become slightly smoother.



Add Infrasound (LF) in the same way. Even with a low-pass filter, the delay time is negligible because the FIR order is as light as 8 and the sampling is as high as 800 Hz. (1 msec group delay)

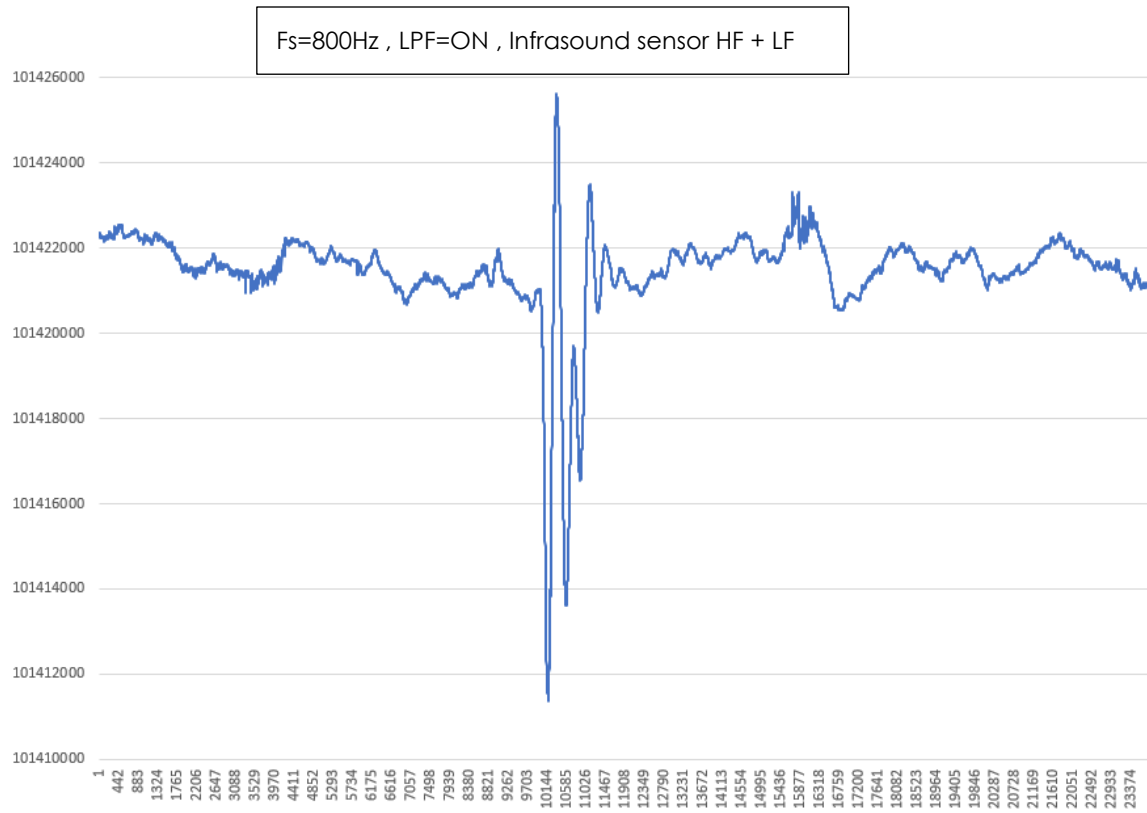

It is a waveform when giving a triangular wave of 20 Pa at 50 second cycle with a dedicated test machine. The HF side has a differentiated waveform, and the amplitude is attenuated by -15 dB. This result is natural because the lower limit of the response frequency is 0.1 Hz.

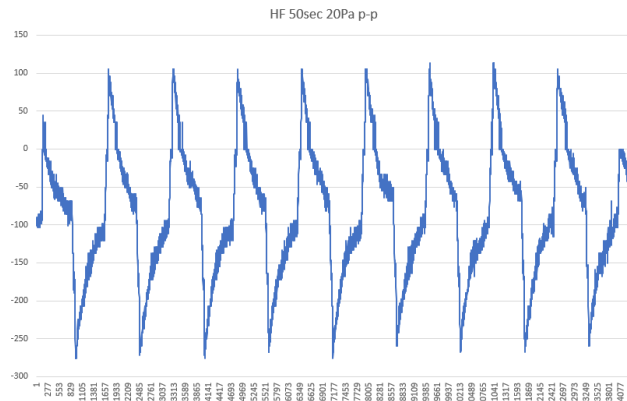

At this time, the waveform of 20 Pa can be clearly confirmed. The upward trend is due to the fact that LF is an absolute pressure gauge. The LF side is better at lower frequencies. In less than 10 seconds, the performance on the LF side instead of HF is advantageous.

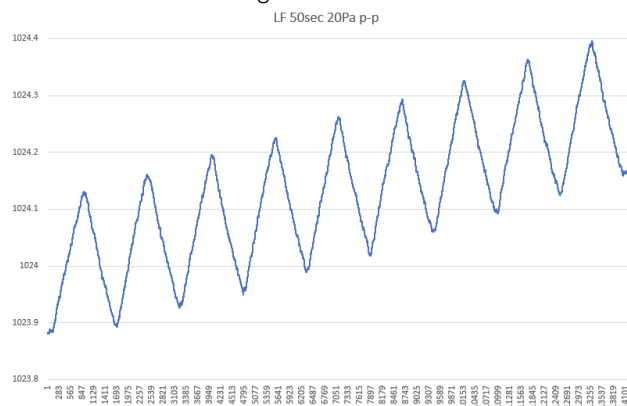

LF + HF waveform. There is no waveform distortion even if it is added because it is a linear phase.

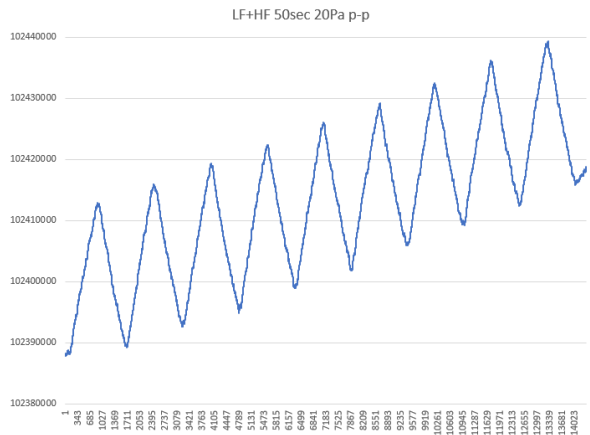

This is the ADXIII-INF01LE waveform when the same 50 second waveform is applied. The waveform is beautifully drawn because the minimum resolution is smaller by one digit or more.

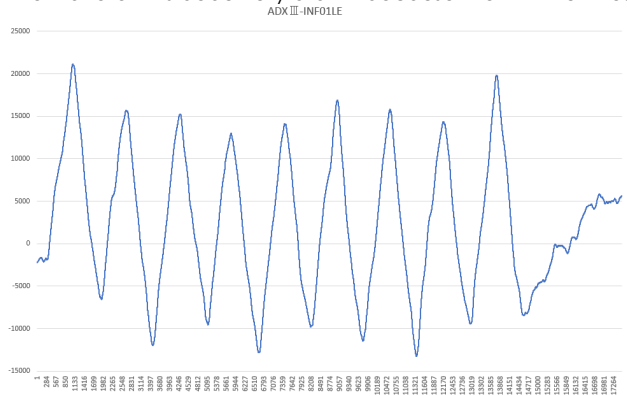

Next, it is a waveform when adding a sine wave of 40Hz 89dB / SPL (approximately 1.5Pa). First is the HF side. There are actually 1900 samples, but it is too detailed to be understood, so the waveforms from the first 100 samples are also included. The center of the entire waveform is a strange waveform.

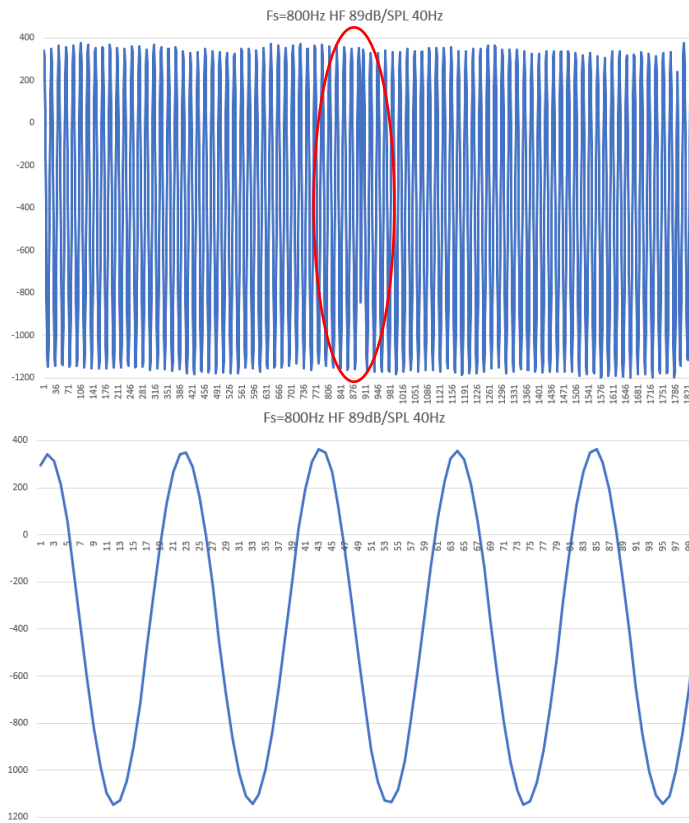

Next is the LF side. As we do not respond in this frequency band, we are capturing changes in barometric pressure roughly. At this time, the pressure change is small and the minimum resolution can be seen. As for the minimum resolution, ADXIII-INF01LE is better by one digit or more.

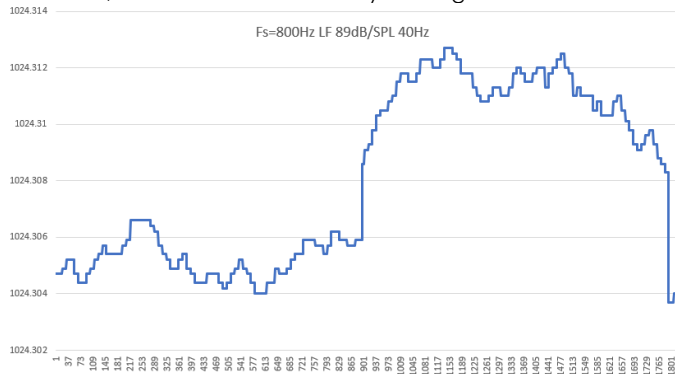

It is a composite waveform of HF and LF. You would see that the mysterious waveform in the middle was made due to the rise of air pressure.

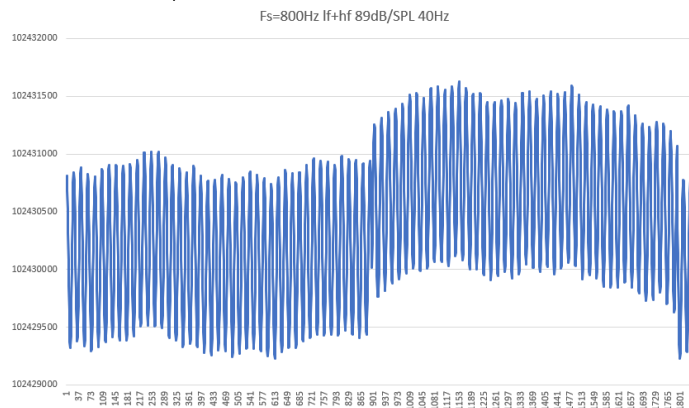

6. Buffer-triger Engine

6.1 Ring buffer (Analog and Counter input)

Acceleration, noise, barometric pressure, 1PPS, analog general purpose input (AI 16bit × 8ch) and infrasound input (AC / DC / temperature) (CTC 32bit × 4ch) are integrated to form 256bit = 32byte = 8double-word composite data. This data is sequentially written to the buffer memory in synchronization with the sampling cycle. The buffer memory is 128 samples in size for acceleration, noise, barometric pressure, 1PPS, analog general purpose input, and infrasound input (AC / DC / temperature). In addition, GPS time data and 16-bit temperature data per respectively are also integrated.

The buffer memory is equipped with 2 banks, and when the buffer being written is full, it performs bank change and enters read mode. In the meantime, it continues writing another buffer memory and continues data collection. At the same time as the bank change, the interrupt register flag is asserted, and then the data in the buffer memory that is full at this timing is read. By circulating and repeating this action, low load and high speed continuous data acquisition can be realized. The buffer size is **4108 bytes × 2 banks**.

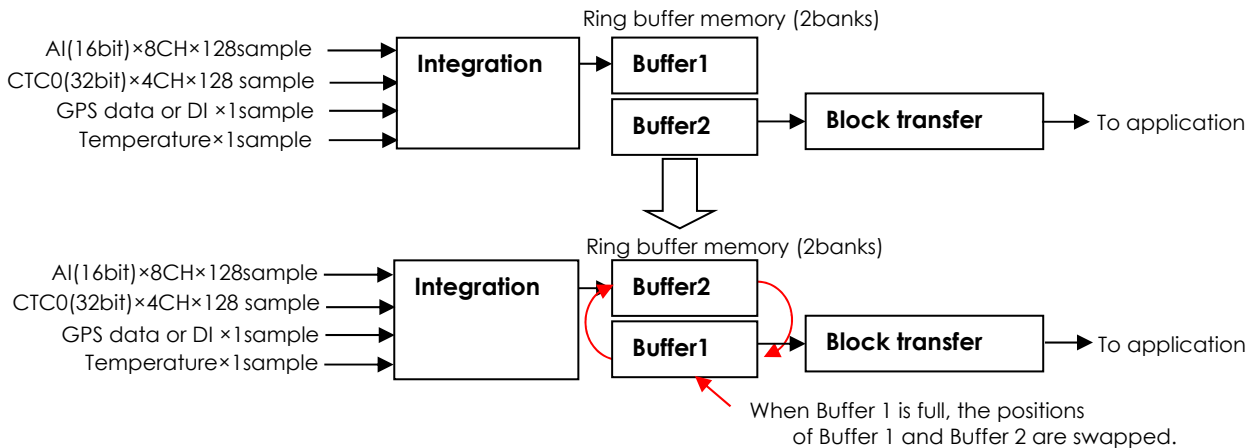

6.2 Multifunctional Trigger Controller

The ring buffer described above can control "start" and "stop" by the trigger controller. Trigger conditions can be set independently with "Start" and "Stop". The trigger types are shown below. To use the trigger, set the trigger mode and associated parameters.

[Trigger mode]

[1] Digital rising edge trigger to digital input of arbitrary channel.

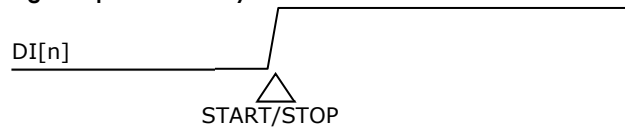

[2] Digital falling edge trigger to digital input of arbitrary channel.

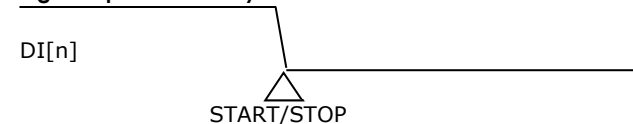

[3] Pattern trigger to digital input (maskable).

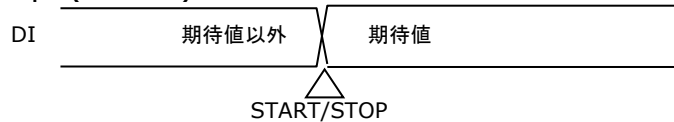

[4] Analog input positive edge trigger

The trigger mode specifies analog level [API definition is AI_LEVEL]. When TRIG_LEVEL1 < TRIG_LEVEL2, trigger the rising at the position b in the right figure. The flank trigger is performed when the analog input exceeds TRIG_LEVEL1 (point a) and at point b where it exceeds TRIG_LEVEL2. The area from TRIG_LEVEL1 to TRIG_LEVEL2 corresponds to the dead band (hysteresis) for noise etc.

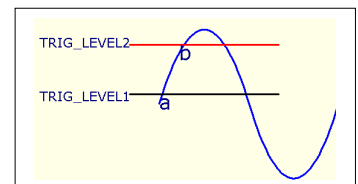

[5] Negative edge trigger of analog input

The trigger mode specifies analog level [API definition is AI_LEVEL]. When TRIG_LEVEL1 > TRIG_LEVEL2, the position shown in the right figure b, the flank trigger is executed. The trigger is executed at "a point" where the analog input falls below TRIG_LEVEL1 and "b point" where it falls below TRIG_LEVEL2. The area from TRIG_LEVEL1 to TRIG_LEVEL2 corresponds to the dead band (hysteresis) for noise etc.

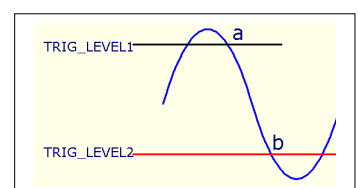

[6] Dual edge trigger of analog input

The trigger mode specifies analog level [API definition is AI_LEVEL]. When TRIG_LEVEL1 = TRIG_LEVEL2, the trigger is executed at the position shown in the right figure b. Triggering is triggered at the point where the analog signal level exceeds TRIG_LEVEL1 (point a) and falls below TRIG_LEVEL2 (point b).

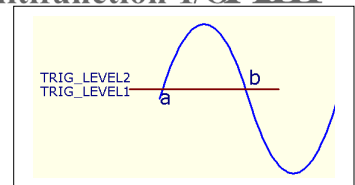

[7] In area trigger of analog input

The trigger mode specifies the analog area [API definition is AI_AREA]. When TRIG_LEVEL1 < TRIG_LEVEL2, the in-area trigger (in-range trigger) is used. Triggered at the point where the analog signal level is in the range from TRIG_LEVEL1 to TRIG_LEVEL2 (point b).

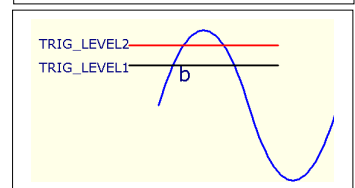

[8] Analog input out-of-area trigger

The trigger mode specifies the analog area [API definition is AI_AREA]. When TRIG_LEVEL1 > TRIG_LEVEL2 is selected, the out-area trigger (out-range trigger) shown in the figure on the right is generated. Triggered at the point where the analog signal level goes out of the range of TRIG_LEVEL1 to TRIG_LEVEL2 (point b).

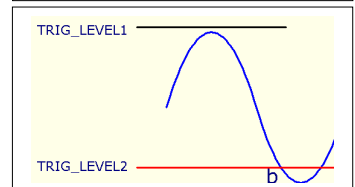

[9] Unconditional trigger

The trigger mode specifies the analog area [API defined is BURST]. The trigger is executed as soon as the ring buffer is started. If this condition is specified in the stop trigger, it will not be used because it will be an unconditional stop. Without using triggers in [1] to [8], this trigger is used as a general action to start data collection with the software start button.

[10] Trigger reset

The trigger mode specifies the analog area [API definition is RESET]. If this condition is specified by the stop trigger, the stop condition will not be met, and the ring buffer will be stopped by software or stopped by the stop counter (described later).

[Stop Counter] In addition to the stop trigger, the stop counter can be used to stop the ring buffer. The loading is automatically ended when loading for the designated bank (= designated capacity) is performed with the ring buffer as one unit = 1 bank. The stop trigger and the stop counter can be used together as they are added logically.

[Trigger delay] Trigger delay starts / stops 0 to 65,536 samples delay data acquisition (ring buffer acquisition). This function can be used to reduce the amount of data if data is not needed for a while after the trigger occurrence.

[Dead time counter] If the start trigger and the stop trigger have the same trigger source, the same trigger mode, and the same condition settings, data collection can not be started because the stop trigger is effective immediately after the start trigger becomes effective. Dead Time Counter avoids this problem by disabling the number of samples specified for stop trigger detection immediately after the start trigger.

6.3 Block polling

ETHERNET is a mechanism to make detailed data request and return a response each time. This will cause a lot of packets to come and go, which will result in a significant decrease in performance. The ring buffer described above can improve performance by transferring large amounts of data with fewer packets by transferring data in large chunks of data. At the same time, non-intermittent continuous data collection is realized by using two banks of ring buffer operation.

However, the ring buffer sends 128 samples of data at one time, so if the sampling frequency is low, real-time performance will deteriorate. For example, with sampling of 0.1 seconds, 12.8 seconds of data waiting occurs, and you have a feeling that it takes time with a trend graph etc. Also, with multiple devices, errors occur in the sampling frequency, the number of data and sampling time do not match, and post-processing becomes difficult. In other words, ring buffer is suitable for high speed operation by itself.

Block polling is suitable for slow multiple operations. Block polling includes 1 sample each for acceleration, noise, barometric pressure, 1PPS, analog general purpose input (AI 16 bit x 8 ch), infrasound input (AC / DC / temperature) (CTC 32 bit x 4 ch), GPS time data, 16 bit temperature data Block transfer together. Since each sample is one, sampling period and timing can be controlled by software, so data can be collected at the same timing even if multiple devices are used. Naturally the response will be faster.

Depending on the environment, when the **ADXIII-INFO4LE** is directly connected to a PC via Ethernet, the deviation from the actual measurement period will increase if the polling measurement period falls below 30 msec. The error increases with the average speed of 28msec at 20msec setting and the average speed of 24msec at 10msec setting. As a rough guide, in the case of Ethernet direct connection, you may decide whether polling or ring buffer should be used or not at 30sec. On the other hand, the maximum speed not overrun frequently with ring buffer is 21 times performance at 700Hz (1.429msec) when directly connected with PC and Ethernet.

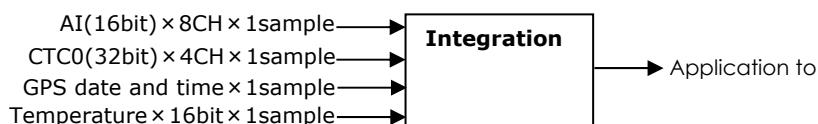

6.4 Sampling timer

The timing of data collection in the ring buffer is controlled by the sampling timer. This sampling frequency is variable and can be varied from 20 KHz to 0.0137 Hz. Even with block polling that does not use a ring buffer, this sampling timer controls the A / D converter etc. Make the sampling timer much faster than the block polling speed.

7. Software

7.1 How to handle this product

There are three ways.

1. Understand the register map and communication algorithm of adiox3regmap.pdf
 Advantages : It can be used on various platforms and operating systems
 Disadvantages : This takes the longest time to develop.
2. Understand Adiox3 API of Adiox3api.pdf and develop only Windows applications
 Advantages : You can develop your own Windows application
 Disadvantages : this takes some time to develop
3. Collect data on Windows using the provided software (MultiLoggerX3)
 Advantages : No development required, data can be collected immediately.
 Disadvantages : The platform is restricted to Windows.

The following sections describe the configuration and driver installation, which are preparations for using 2 and 3 above. The driver includes a dynamic link library that exports ADiox 3-API. As development environment, header file and import library for C / C ++ language, definition file for VisualBASIC, definition file for VisualC #, sample source for each language, attached application and its source etc. are provided.

7.2 Configuration Ethernet mode

The IP address and port number at shipment are as follows. Change this if necessary.

IP address : 192.168.1.31
 Port number : 9004

Step 1: Match the address groups of PC and initial ADXIII-INF04LE.

Connect the network with the PC and turn on the power. Open the "Change adapter settings" screen of the Windows network, and double-click the network adapter to which this product is to be connected.

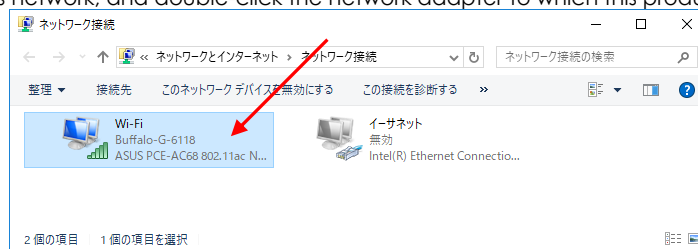

Click the "Properties" button at the bottom.



Double click "Internet Protocol Version 4 (TCP / IPv4)".

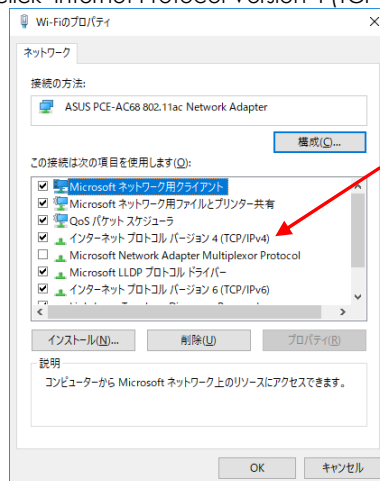

In the screen below, align the IP address with the address group (192.168.0.xxx) of this product.

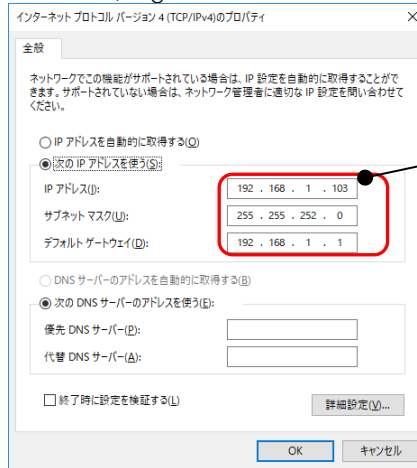

Alternatively, you may set the automatic assignment to "192.168.0.xxx" in "DHCP" and the exclusion address to "192.168.0.2".

Even if the IP address on the PC side is "192.168.1.xxx", if the subnet mask is "255.255.252.0", you can access "192.168.0.xxx".

Step 2: Change the settings on the ADXIII-INF04LE side.

Access the initial address of this product with a web browser. Click the "OK" button without entering any username and password.

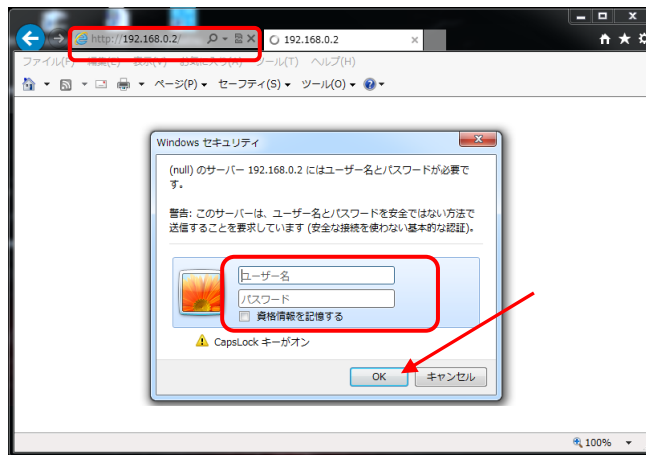

The setting screen will appear. Please do not change anything other than the one we explained, as there is a risk that you will not be able to communicate.

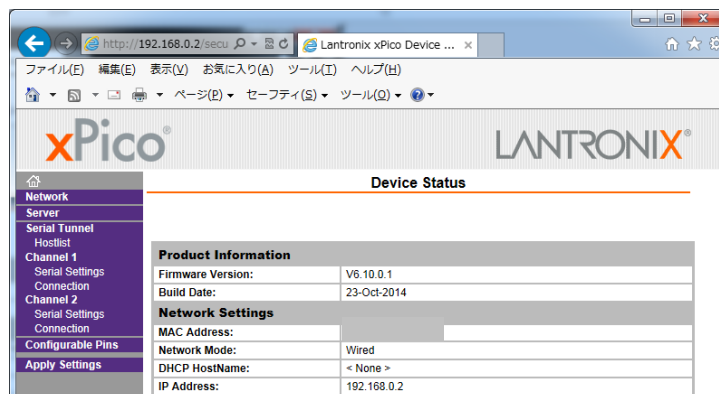

To change the IP address, subnet mask and default gateway, click the left menu Network to open the setting page. Write the parameters you want to change in the IP Address, Subnet mask, DefaultGateway, and DNS Server items on the right panel in half-width numbers, and click the OK button below at the end. (If the value is .undefined.undefine, please set it with 7.3 DeviceInstaller.

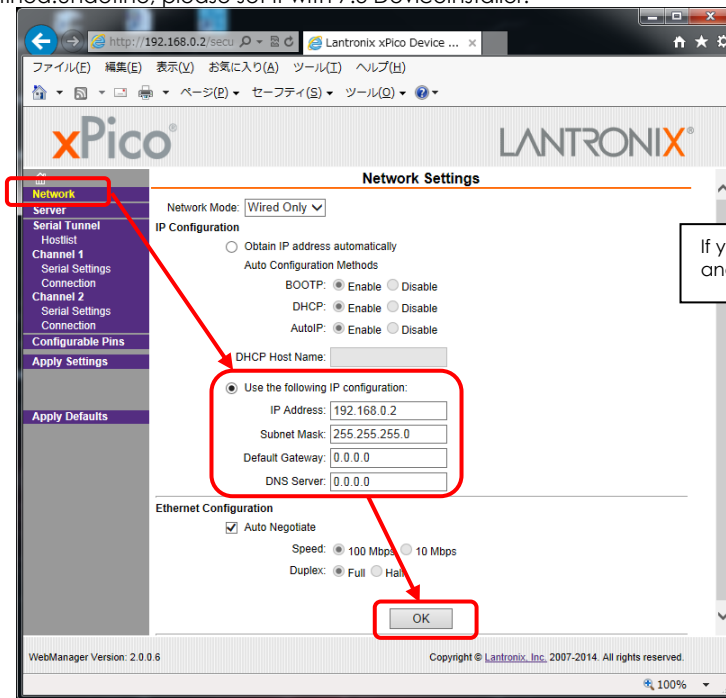

If you do not use default-gateway and DNS, please enter 0.0.0.0.

To change the port number, click Channel 1 → Connection on the left-side menu, write the parameter you want to change to Local Port: in the center of the screen on the right-hand panel in half-width alphanumeric characters, and finally click the OK button at the bottom.

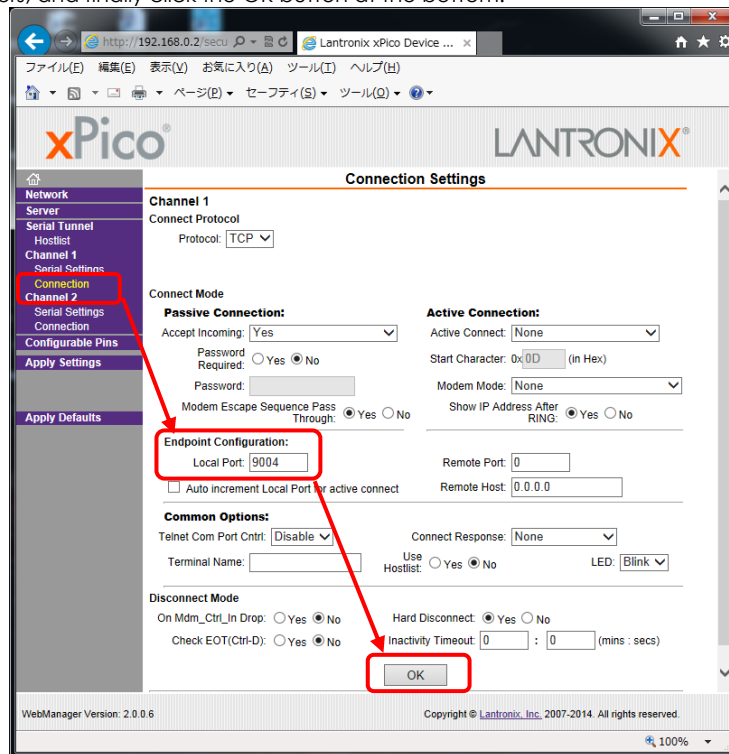

The previous settings changes will be reflected in the hardware after clicking ApplySetting on the left side menu. If you exit without clicking ApplySetting, your settings will not be reflected. **Please do not change the setting of the part that is not described above. Otherwise, you may not be able to communicate.**

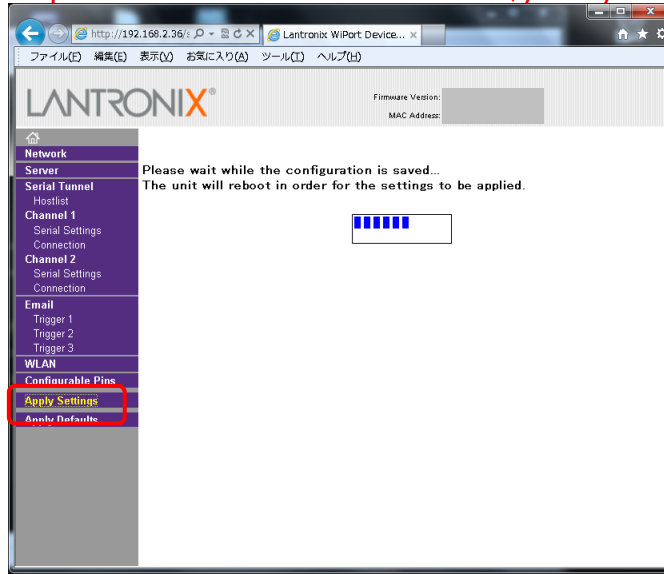

Step 3: Set the PC side to the setting of ADXIII-INF04LE.

If the IP address group of this product has been changed, turn the power on again, return to step 1 to step 2, match the address group, and reconnect.

Step 4: Match the application address

Finally, match the address of the application such as MultiLogger X3 with this product. Please refer to the manual of this software for details.

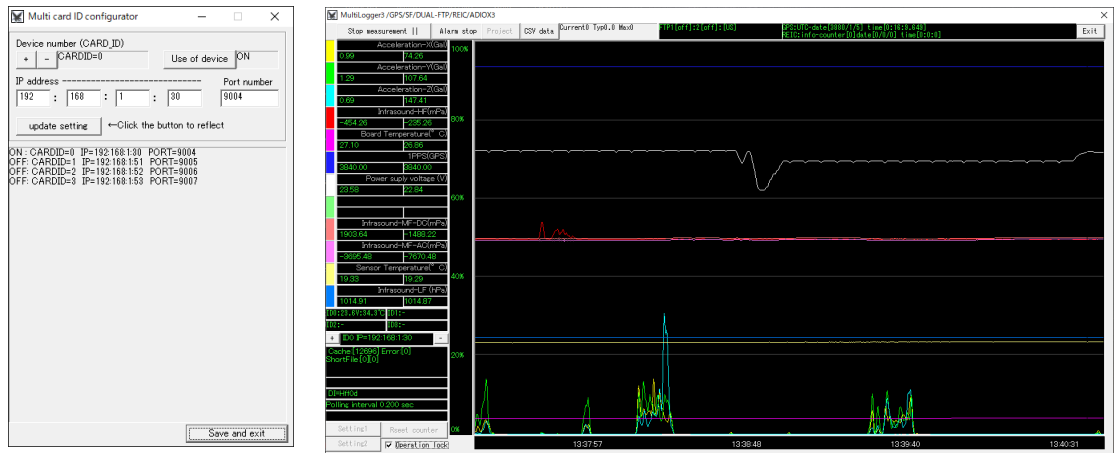

7.3 Configuration of RS232C (UART) mode

Check the COM number that connects the infrasonic sensor in the Windows device manager.

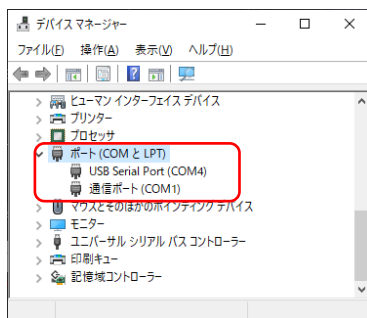

Start the configurator "**MultiCardIDConf.EXE**" and make settings related to the serial port. Specify the COM number and speed (115.2Kbps or 921.6Kbps) depending on the hardware you are connecting to. The buffer size is default Large (4096). If that doesn't work try Small(14).

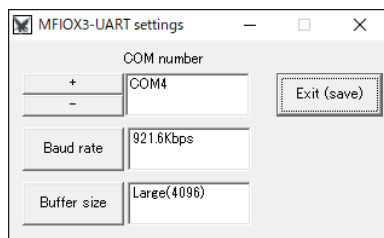

7.4 Driver Installation Method

Copy the DLL to the same folder as the application that handles this board. Copy source is

ETHERNET

32Bit Windows

CDROM¥sdk¥driver¥dll_x86

64Bit Windows

CDROM¥sdk¥driver¥dll_x64

RS232C(UART)

32Bit Windows

CDROM¥sdk¥driver¥dll_x86u

64Bit Windows

CDROM¥sdk¥driver¥dll_x64u

Now you can use the supplied application (MultiLogger X3) and the development environment (ADiox3-API).

7.5 Usage of application and API, description of register map

These are not described in this document, so please refer to the following.

1. Please refer to adiox3regmap.pdf for the register map.
2. API, please refer to adiox3api.pdf.
3. Please refer to multilogger_x3.pdf for how to use Supplied App MultiLogger X3.

7.6 DeviceInstaller

If you see the following when opening the target configuration screen, you can not set it correctly. Therefore, please close the browser as soon as possible, execute Tool ¥ DeviceInstaller ¥ setup.exe on the CDROM, and install it. (This method can not be used in the Wi-Fi version)

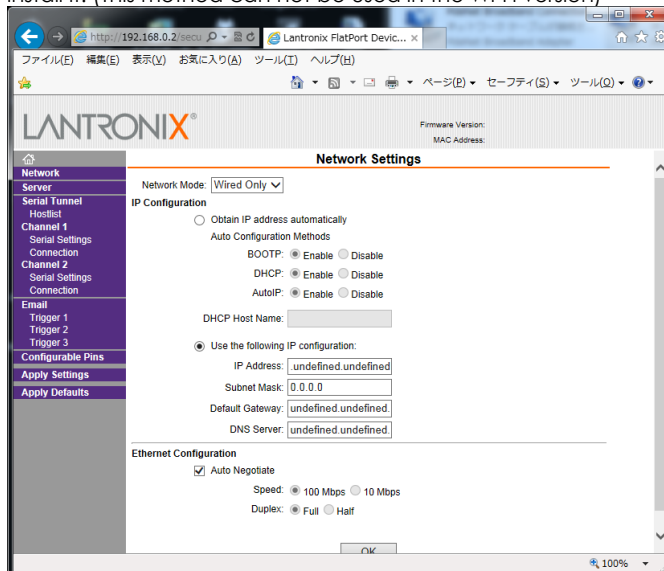

Launch the installed DeviceInstaller by double-clicking it. After a while, the address of **ADXIII-INFO4LE** on the local area network is listed on the right side of the screen as shown below. Double-click this listed line.

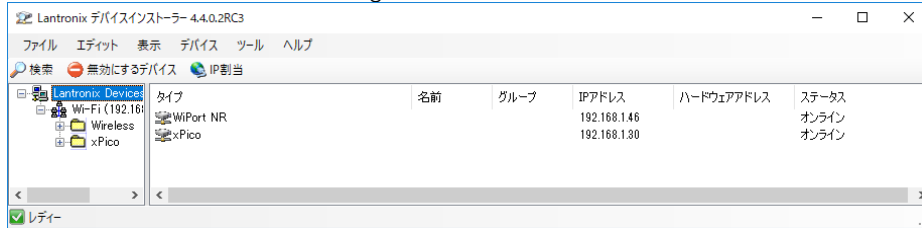

Then the screen changes as follows, and the status regarding communication etc. is displayed. There is a tab at the top, so click on the web configuration in this to select it.

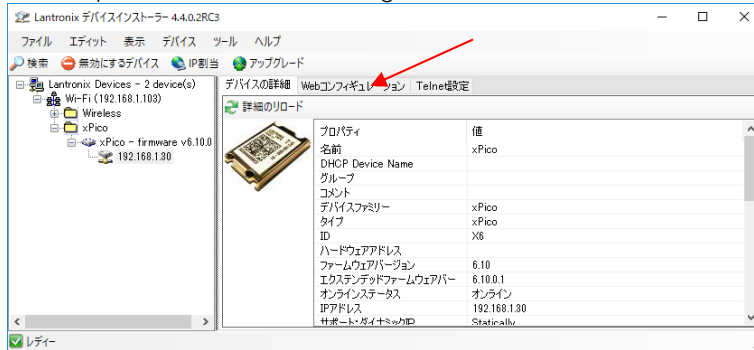

Then click the green right arrow button (GO button) at the top of the web configuration screen.

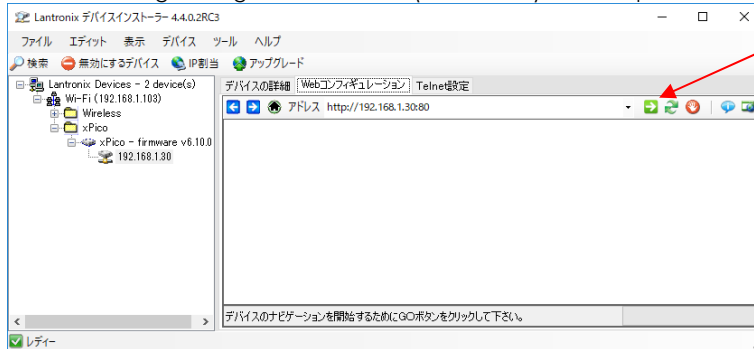

After a while, the following dialog pops up, so click the OK button without entering any username and password.

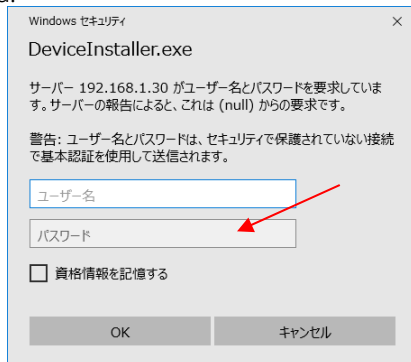

After a while, the right side of the screen below will be the first screen of Explanation 7.1. After setting is complete, please close this application.

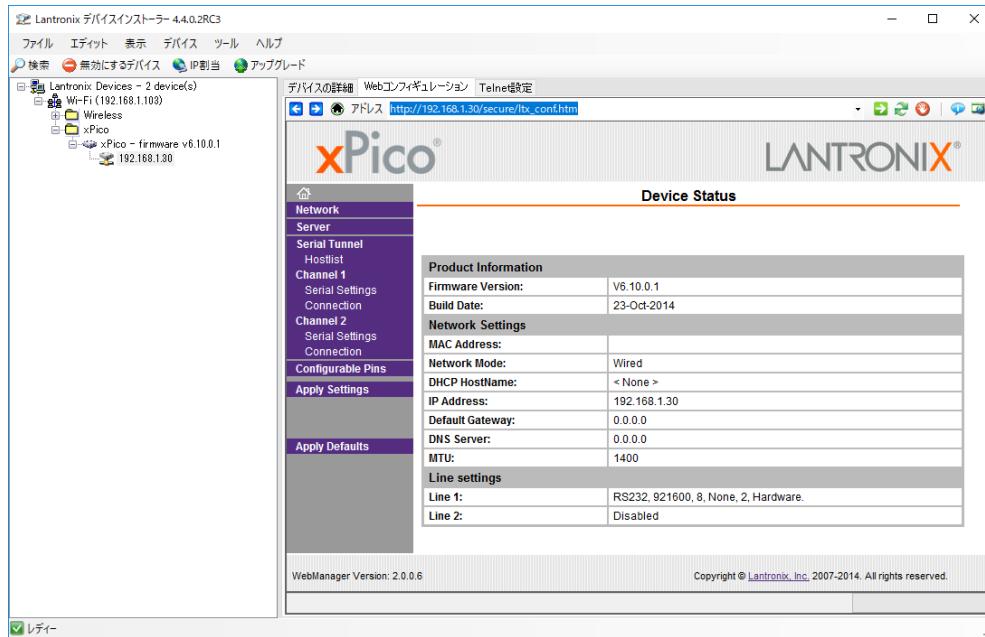

7.7 Maintenance of communication environment

In order to avoid problems such as inability to communicate with the [ADXIII-INF04LE](#), disconnection in communication during the operation, and inability to reconnect, it is necessary to maintain a communication environment.

Firewall software setting 1.

Make the IP address and port of the target ADXIII-INF04LE available for both TCP/UDP transmission and reception. (Exception processing, permitted ports, trusted addresses etc. For details, refer to the instruction manual of the fire wheel software)

Firewall software setting 2.

Please allow ICMP by sending / receiving. This is to make it possible to handle PING packets freely.

8. Cautions, etc.

General prohibition matters

Avoid use in an environment harmful to electronic devices. High temperature, high humidity, rapid temperature change (condensation), static electricity, corrosive gas (including strong acid and strong alkali), conductive dust, vibration, stress to substrate, shock, over voltage, reverse voltage, short circuit, output terminal Overload, short between outputs, large amount of electromagnetic wave of wavelength shorter than ultraviolet light, mold, strong electric field, strong magnetic field etc. Use under such circumstances is not covered by the warranty or support. In addition, please fully verify it when incorporating it into the system.

Handling of this specification

<Product differences>

We strive to make this specification easier for users to understand, but if this specification differs from the product, the priority is given to product. In addition, the product will be prioritized in the same way for the subjective interpretation of this specification.

<Quality and Function>

We do not guarantee that the quality and function of this product will fit your intended use. Therefore, you are responsible for the selective introduction of this product, and the same applies to the use of this product and any direct or indirect damages resulting from it. Therefore, please fully verify it when incorporating it into the system.

<Version upgrade>

We offer version upgrade and correction of drivers and specifications by web, email, CDROM distribution etc. However, due to various circumstances of our company, we may not be able to take prompt action. In addition, these are not obligated to our company.

Long term storage

If this product is stored for a long time, it may corrode in a short time due to condensation or hydrogen sulfide gas generated from cardboard. To prevent this, please store in a non-condensing environment and package with vinyl etc. so that corrosive gas can be shut off. In addition, after long-term storage, please use after aging for 2 to 3 hours.

Comprehensive reliability test etc

This product is integrated into the PC and higher devices, and works in conjunction with it. For this reason, the ability to handle various conditions such as temperature cycling and electrostatic breakdown is greatly affected by the PC and the entire device. In addition, the required environmental adaptability also differs depending on the temperature, humidity, temperature change, ventilation conditions, dust conditions, electromagnetic wave conditions, and vibration of the operating environment. Therefore, if reliability on these embedded systems is required, it is necessary to conduct separate comprehensive tests to confirm that they can withstand the specification environment.

Industrial property rights, copyright

If there are problems with industrial property rights and copyrights of third parties due to the use of this product, we will not be liable for any issues other than our production and manufacturing issues. Please understand that. Also, without our permission, we prohibit reverse engineering of circuits, programmable device configuration data, on-board EEPROM, and driver software. We are not liable for any damages resulting from this.

Purpose of use

Please contact us when considering applications that require extremely high safety, such as medical devices that directly affect human life such as transportation equipment (cars, trains, ships etc.), traffic signal control, disaster prevention and crime prevention equipment, aircraft, space equipment, submarines, submarine relay equipment, nuclear power plants, military equipment.